

# **How to use ripple signals on Orion's network**

**Revision 6  
Issued 3 February 2012**

**NW70.26.02**

## Table of Contents

<b>1</b>	<b>Introduction</b>	<b>3</b>
<b>2</b>	<b>Controlling load</b>	<b>4</b>
2.1	Mandatory control of water heaters	5
2.2	Requirements for other types of heaters	5
2.3	Alternative control systems	6
2.4	Orion's commitment to ripple control	6
2.5	New channels	7
<b>3</b>	<b>Ripple control categories</b>	<b>8</b>
3.1	Peak control	8
3.2	Fixed time control	8
3.3	Emergency control	9
3.4	Special purpose channels	9
3.5	Obsolete channels	9
<b>4</b>	<b>Functional wiring options</b>	<b>11</b>
<b>5</b>	<b>Technical details</b>	<b>13</b>
5.1	Telenerg and Decabit coding systems	13
5.2	Area specific control channels	14
5.3	Signal strength and receiver sensitivity	15
5.4	Random allocation of channels	15
5.5	Switching delays	15
5.6	Relay labelling	16
5.7	Intended channel usage	16
5.8	Override or boost switches	16
<b>6</b>	<b>Ripple relay programming</b>	<b>17</b>
6.1	Programming Telenerg relays	17
6.2	Programming Decabit relays	19
	<b>Appendix A – Orion ripple control coding by area</b>	<b>22</b>
	<b>Appendix B – Telenerg / Decabit boundary</b>	<b>23</b>
	<b>Appendix C – Ripple receiver control channels</b>	<b>24</b>
	<b>Appendix D – Ripple receiver fixed switching times</b>	<b>27</b>
	<b>Appendix E – Historical channel reference</b>	<b>30</b>

Disclaimer: Orion uses reasonable endeavours to maintain its ripple injection and electricity delivery systems, but these services are not guaranteed. From time to time, intended ripple signals may not be provided or may occur at times that differ from published switching times. Orion expressly disclaims any liability for direct or indirect losses associated with the use or otherwise of its ripple signals.

This is a public document which is published and updated on our website: [www.oriongroup.co.nz](http://www.oriongroup.co.nz). For further information, email Orion at [info@oriongroup.co.nz](mailto:info@oriongroup.co.nz) or phone our Contact Centre on 0800 363 9898.

## How to use ripple relays on Orion's network



### 1 Introduction

Orion New Zealand Limited (Orion) owns and operates the electricity network in central Canterbury between the Waimakariri and Rakaia rivers, and from the Canterbury coast to Arthur's Pass. Our network covers 8,000 square kilometres of diverse geography, including Christchurch city, Banks Peninsula, farming communities and high country regions. We receive electricity from Transpower's national grid at ten different locations and we distribute this electricity to more than 192,000 homes and businesses.

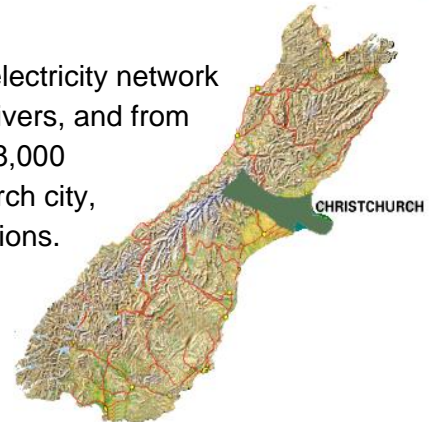

New Zealand's South Island

Within our electricity delivery service, we operate a ripple injection system for the purpose of:

- managing peak loading on our network and on Transpower's grid,
- lowering load following faults or failures, and to facilitate planned maintenance,
- switching on hot water cylinders and night store heating loads during cheaper night periods,
- signalling higher priced congestion periods,
- switching dual rate (eg day/night) meter registers,
- switching street lighting on and off, and
- switching load in response to retailers' requests (from time to time).

This guide is intended for use by electricity retailers and their metering providers and contractors. It sets out the general information and the intended use of the ripple channels we operate, as well as technical programming requirements, with the aim of ensuring a dependable service for all parties.



Modern Enermet R03 ripple relay  
(with Telenerg coding)



Older style Zellweger RM3  
ripple relay  
(with Telenerg coding)

## 2 Controlling load

Orion's control of load has developed over many years and is primarily driven by the desire to provide an economic and reliable delivery system.

### *An economic delivery system*

Like roads, electricity networks experience “rush hours” where loading levels peak and capacity is fully utilised. Orion's rush hours typically occur on cold winter evenings when people arrive home from work and turn on their lights and heaters. On the other hand, our peak loads in our rural network occur during summer months because of the high levels of irrigation pumps connected to our network.

One solution to cope with these relatively short periods of peak loading is to expand our network's capacity – much like making roads bigger to handle more traffic. But this is very expensive, especially given that the additional capacity is not needed 98% of the time, and would mean we would have to increase our prices to cover costs. We think it makes better sense to promote other cheaper options, such as load management.

We use our ripple control system to manage load in a number of ways:

- Directly through dynamic control of supply to appliances, mainly hot water cylinders. This “peak control” shifts the heating load to occur just after the peak. We aim to turn cylinders off for short periods only, to prevent any noticeable effects on customers' hot water supply. We then turn the cylinders back on when network demand reduces.
- Directly through fixed time control of supply to appliances, mainly hot water cylinders and night store heaters, by switching them on during off-peak night periods only. This “fixed time control” permanently shifts load away from the day time periods when peaks occur.
- Indirectly through pricing incentives that reward retailers' customers who lower the amount of electricity they consume during our high priced peak period. We provide ripple signals to tell customers that it's a peak period so that they can reduce their load and reduce their charges – this arrangement is more useful for larger business connections with special half-hour interval metering that records the reduced loading level during the peak period.

### *A reliable delivery system*

We also use load control to enhance the security of our electricity supply. Outages can often be avoided by lowering loading levels for planned maintenance or when faults occur. Even following outages, we can often restore supply more quickly when loading levels are reduced through load management.

To support this enhanced security of supply, and recognising that it benefits all customers, we have made it compulsory to install controllers on all storage water heaters (see 2.1 below). For customers that want a near-continuous supply for their water heater (and don't want regular peak control or night rate options), we have emergency control channels that we operate only during an emergency that threatens supply.

## 2.1 Mandatory control of water heaters

Our network code sets out all the technical requirements that consumers connected to our network must meet. One of these requirements is that storage water heaters must be fitted with a suitable control device to provide peak control, fixed time control or emergency control of the appliance.

Currently, Orion has approved the following ripple receivers as "suitable control devices" for the purpose of meeting this requirement:

- Zellweger and Enermet RM3
- Enermet RC5000
- Enermet RO3
- Zellweger RE1 (approved for existing use only, and should not be used in new connections or as replacements)
- Arc Innovations:
  - 2030 GSM RR Controller
  - 2040 RFM RR Controller
  - 2050 Controller
  - 2051 RFM External Coms Module

In summary, all residential and commercial hot water cylinders of 100 to 500 litres storage capacity with a heating element of more than 1.2kW must be ripple controlled.

There are some exceptions (eg for existing properties without control). Refer to our network code for further details.

## 2.2 Requirements for other types of heaters

### *Other water heaters*

Water may be heated via dual fuelled (eg solar + electric or wetback + electric) systems or via heat pumps. Where there is 100 to 500 litres storage capacity with an electric heating element of more than 1.2kW then Orion's mandatory requirements apply and a ripple relay must be fitted to control the heating element.

Our mandatory requirement for ripple relays does not apply to swimming pools or spa pools.

## Space heaters

Orion provides a number of fixed time ripple control channels that are suitable for storage space heaters (night store heaters) and these channels provide a switching service that is generally more reliable than time-switches. Use of these channels is optional.

Our current ripple control channels are not suitable for use with “on demand” heaters, such as heat pumps.

### 2.3 Alternative control systems

Orion welcomes and encourages the advances in metering technology, and the benefits through enhanced functionality and features that are being made available to consumers.

The management of peak loading and the coordinated (centralised) switching of night loads are vital for the stable operation of our delivery service. The injectors and receivers associated with ripple signalling have been developed over many years and present a highly reliable method of managing load.

It is important that any alternative solutions that either switch the same load that we currently control, or displace our control, are carefully integrated within our system. It is particularly important to consider the reliability of any alternative in an emergency situation (eg, will it work during widespread outages), and the ability to centrally coordinate the switching of loads (to ensure that not too much load is switched on or off at one time).

The provision of our ripple service is covered in our contractual agreements with electricity retailers. If you are intending to develop or implement any alternative system, you must work with Orion to ensure the electricity supply to our community is not threatened. We undertake to respect the commercial sensitivity of any information provided and to proactively develop solutions that allow the coordinated integration and stable transition to suitable alternative systems.

### 2.4 Orion’s commitment to ripple control

Orion recognises the investment made by electricity retailers and their metering providers when installing and maintaining ripple relay receivers. We also recognise the investment made by customers that install storage water heaters to accommodate peak control or night-only heating.

It is our intention to continue our ripple injection service in the longer term and we have recently invested in new ripple injection plant that has a life of more than 20 years. We also have a contractual commitment in our delivery services agreements with retailers to continue with our ripple injection service.

## 2.5 New channels

We have the facility to add new channels to our ripple injection service. These can be operated to a timetable or manually initiated via our 24 hour control centre. There are some costs in establishing new channels and we may apply a small charge to cover any costs associated with operating the channel. Please contact Orion if you wish to discuss this option.

### 3 Ripple control categories

Our ripple channels are grouped into five functional categories:

- peak control,
- fixed time control,
- emergency control,
- special purpose channels, and
- obsolete channels.

The general purpose of each category is described below, specific channel allocations, operational and programming details are provided in appendix C, and fixed switching times are provided in appendix D.

#### 3.1 Peak control

We operate peak control channels to limit or reduce load during periods of peak demand. We also occasionally use peak control channels to limit load when faults occur and to facilitate maintenance.

Our network peaks generally occur on cold winter weekday mornings and evenings. Some localised peaks occur in the late evening (when night loads switch on), and during summer months (when rural irrigation loads are high).

Our peak control channels are intended to control the supply to storage water heaters (hot water cylinders) and we set service level targets to provide sufficient supply to ensure that customers have adequate hot water.

These channels are usually associated with the lower priced 'controlled' or 'economy' type retail tariffs as electricity retailers recognise the reduced contribution to peak delivery charges when setting their prices.

In addition to the main set of peak control channels, we also provide a separate option with more limited control. We operate this option to a different service level target which limits the duration of control and the channels are intended for business connections that can accommodate only limited switching of their water heaters.

#### 3.2 Fixed time control

Fixed time control channels are provided to permanently shift load away from periods of peak demand and to also take advantage of the generally lower electricity costs during nights and weekends.

The channels are intended for larger storage water heaters (hot water cylinders), and storage space heaters (night store heaters). Boosted and weekend boosted channel options are available for customers with greater heating requirements. Our current fixed switching times are provided in appendix D.



These fixed time control channels are usually associated with the lower priced ‘*night only*’, or ‘*day/night*’ type retail tariffs as electricity retailers recognise the reduced contribution to peak delivery charges, as well as the lower energy costs when setting their prices.

### **3.3 Emergency control**

Emergency control channels are provided for customers that require a near-continuous supply for their water heater. It provides the opportunity for us to interrupt supply during emergencies in order to avoid total supply failures.

We provide two water heating channels, one for residential connections, and the other for business connections. Supply interruptions tend to have a more significant impact on business customers and we will aim to restore supply to the business connection channel first.

We also operate a range of emergency control channels for irrigation connections which are associated with our ‘interruptibility rebate’. See section 5.2 for more details.

### **3.4 Special purpose channels**

We provide a range of special purpose channels that have specific functions, including:

- meter register switching,
- pricing period notifications (peak periods, control periods and generation periods),
- switching of street lighting, and
- switching of customer owned relay receivers.

See appendix C for details.

### **3.5 Obsolete channels**

As requirements change and new functionality is introduced, existing ripple receiver control channels may become obsolete. To maintain service for existing users of channels that become obsolete, and recognising the investment by ripple relay owners, Orion will endeavour to provide at least 5 years notice (unless agreed otherwise) before withdrawing the channels.

The schedule of ripple relay command channels (appendix C) includes a section of obsolete channels. With the rationalisation of ripple channels undertaken in early 2007, these channels are no longer required as they provide the same functionality as other current channels. We will continue to inject signals to operate ripple relays using these obsolete channels until at least December 2012.

Whenever the opportunity arises, existing ripple relays that use these obsolete channels should be removed or re-programmed to use current channels. It would also be an advantage to record connections that have these relays to facilitate a transition to current channels at a later date.

Over time, Orion and its predecessors have maintained a range of ripple channels. Appendix E provides a reference of previous names, and together the matching current option.



**Orion's 11kV ripple injector at the  
Heathcote district substation**

## 4 Functional wiring options

Our ripple control channels may be used in a number of different ways and wiring configurations. This section provides functional diagrams for the most common wiring configurations that comply with our mandatory control requirements (see section 2.1).

The diagrams show only the *functional* configuration. Wiring details (ie switching, fusing, method of isolation, neutrals and their location etc) are not shown. All wiring must comply with statutory regulations and codes of practice.

Orion has fuses located in many meter boxes in the Christchurch urban area which are required for regulatory safety reasons (ie electrical protection and isolation in the event of emergencies). Orion owns and is responsible for these fuses but is not responsible for the downstream wiring. Orion must approve any moving or removal of these fuses and a compliance certificate and inspection is required in relation to such work.

The switches in the following diagrams are numbered in order to reference their function (noted below each diagram). The numbers do not represent commonly used switch positions.

The channel codes for the ripple switches (eg P1 etc) can be found in appendix C.

### *Single register meter with controlled water heater*

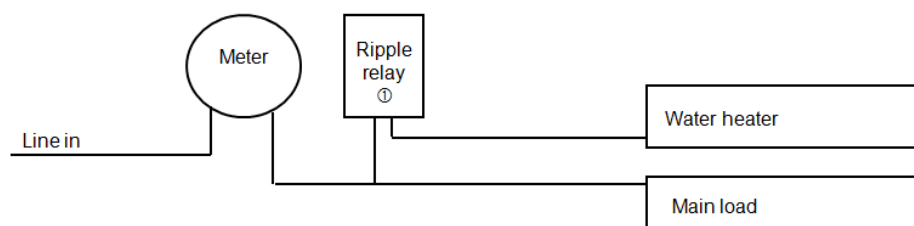

Ripple switches

- ① Peak channel (P1 or P2) or emergency control channel (E1 or E2)

### *Dual register meter with switched load (and optional customer bypass switch)*

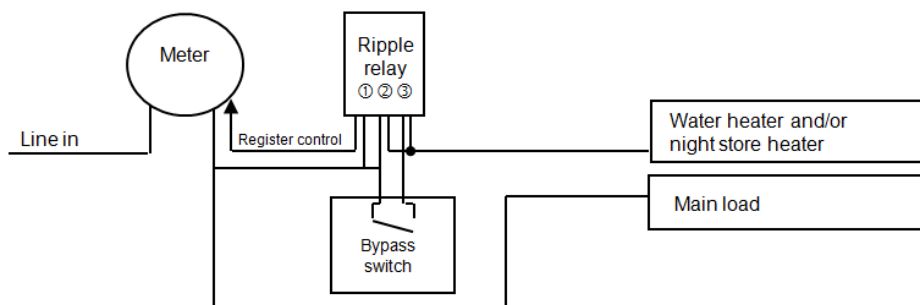

Ripple switches

- ① Meter register channel (S9 or S10)
- ② Fixed time control channel (F1, F2, F3, or F4)
- ③ Peak channel (P1 or P2) or emergency control channel (E1 or E2)

*Two single register meter with switched load*

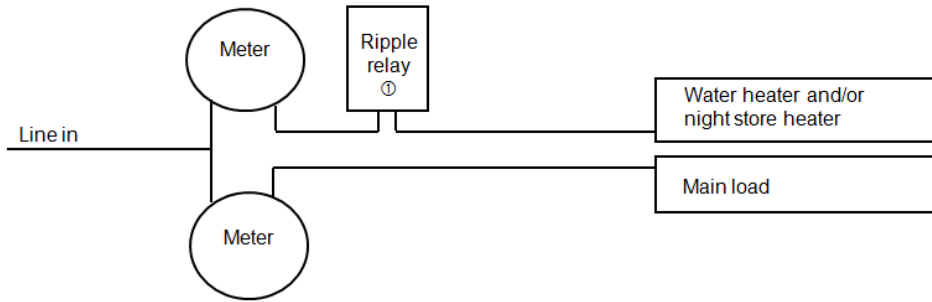

**Ripple switches**

- ① Fixed time control channel (F1, F2, F3, or F4)

## 5 Technical details

### 5.1 Telenerg and Decabit coding systems

Orion operates two ripple coding systems:

- Telenerg, based on 11kV injectors using a 175Hz carrier frequency which operates mainly in the urban Christchurch and Lyttelton areas, and
- Decabit, based mainly on 33kV injectors using a 317Hz carrier frequency which operates in the rural Canterbury and Banks Peninsula.

We do not provide ripple injection signalling in our three remote network areas, Arthur's Pass, Castle Hill and Coleridge. For these areas, we recommend the use of smart meters or time clock switches for the purpose of switching meter registers and loads.

With the two coding systems, it is important that the correct frequency and relay types are installed in the correct areas, particularly near the boundary between the areas. In most situations, relays will not work if installed in the wrong area.

Appendix A to this document provides a schedule of the coding system that is supported in each grid exit point area. To establish which coding system should be used for individual connections, simply cross-reference this schedule with the grid exit point recorded for the connection on the Electricity Authority's *Registry*. Alternatively, the coding system is provided with the details for each connection on the "Search ICP" page on our website, see

[www.oriongroup.co.nz/your-network/retailers/search-icp.aspx](http://www.oriongroup.co.nz/your-network/retailers/search-icp.aspx).

As an alternative, the map in appendix B shows the geographic area for the two coding systems, but this should not be relied upon in areas near the boundary.

#### *Boundary changes*

Orion is actively managing and maintaining its ripple injection equipment and this work has resulted in some changes to the boundary between Telenerg and Decabit coding areas.

Specifically, the Telenerg coding area has expanded around the Hornby / Islington area, replacing the existing Decabit coding. To accommodate this change we have provided a transition period, during which both Telenerg and Decabit signals will continue to be provided, and we will work to negotiate equitable transition terms or notice periods with affected parties.

Appendix A provides details of areas where we are maintaining Decabit signals as part of this transition period, together with the expected duration of the transition period. In these areas, please ensure that Decabit relays are replaced with Telenerg relays whenever the opportunity arises (for example, when performing tariff changes or metering upgrades).

## 5.2 Area specific control channels

### *Irrigation interruptibility*

Orion provides an optional “interruptibility rebate” which is paid to irrigation customers that agree to have a ripple relay installed to switch off their irrigation pump during emergencies. This arrangement is only available for irrigation connections fed from our Springston or Hororata grid exit points (within our Decabit area) and Orion allocates the ripple control channel on a connection-by-connection basis, within the broad geographic areas as follows:

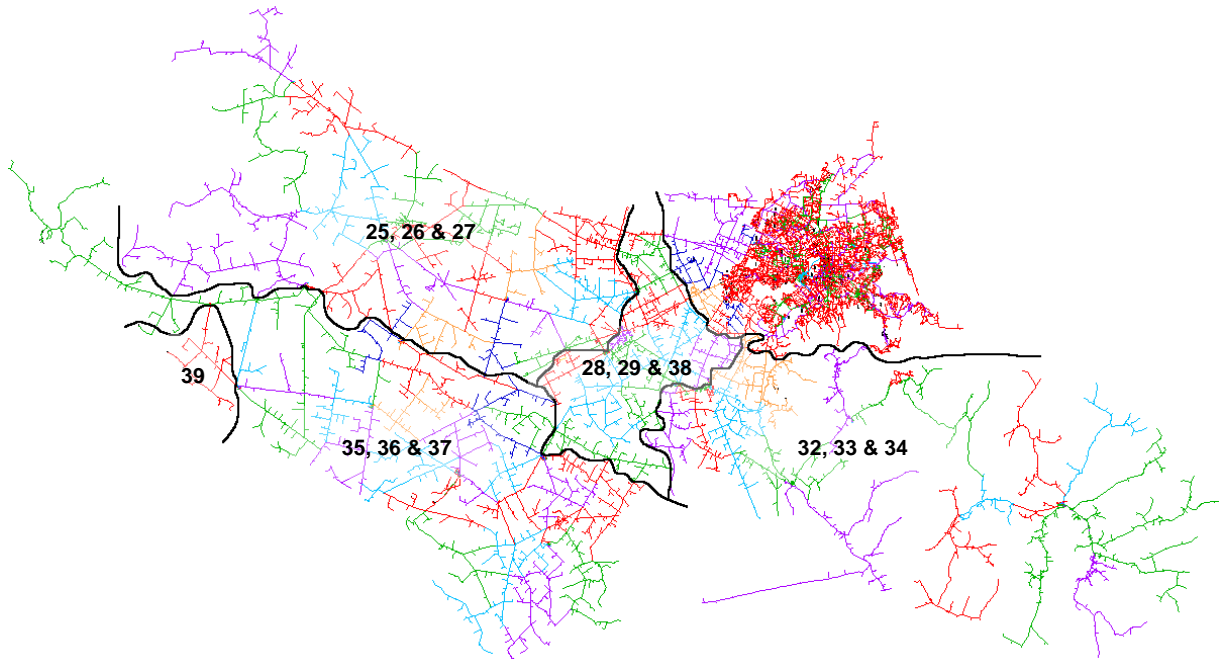

To establish which ripple control channel to install, please call our contact centre on 0800 363 9898. Alternatively, you can look up the control channel coding using the “Search ICP” facility on our website (see [www.oriongroup.co.nz/your-network/retailers/search-icp.aspx](http://www.oriongroup.co.nz/your-network/retailers/search-icp.aspx)). We are also able to provide bulk schedules showing the control channel coding on request.

Please ensure that Orion is notified of all ripple relay changes affecting this interruptibility arrangement. Orion regularly audits all irrigation connections and will remove rebates for non-compliant connections. Further information on our interruptibility rebate is available from the pricing page on our website (see [www.oriongroup.co.nz/publications-and-disclosures/pricing.aspx](http://www.oriongroup.co.nz/publications-and-disclosures/pricing.aspx)).

### *Previous area-specific codings*

In the past, Orion and its predecessors have defined specific coding requirements based on geographic areas to enable focused load shedding – these area coding requirements are no-longer required. Specifically:

- The Decabit peak water heating control command channel “00” was previously reserved for relay receivers installed on Banks Peninsula. The “00” command channel should now be randomly assigned (along with the other peak control command channels) throughout the Decabit area, and new ripple relays installed on Banks Peninsula should be randomly drawn from the full set of peak control command channels.
- The Telenerg area in urban Christchurch was previously separated into 9 areas (with area codings A to F, H J and K). All new ripple relays installed in the Telenerg area should be programmed to area code A (by default). Ripple relays with other area codes will continue to operate indefinitely and may be re-installed anywhere in the Telenerg area.
- Our summer peaking rural network, referred to as “zone B”, was previously separately controlled during summer, with dedicated peak period and control period ripple channels. We now operate these existing channels to signal the network-wide winter based peak periods and control periods.

### 5.3 Signal strength and receiver sensitivity

In the areas where ripple injections are provided, we undertake to provide these signals at each network connection point with a strength of at least 0.55% of the carrier voltage, and this signal strength can vary up to 1.75% (ie between 1.26 volts and 4.03 volts). Ripple relays must be designed and tested to operate reliably within this range.

To avoid nuisance switching from interference, ripple relays must also be designed and tested to ignore signals below approximately 0.3% (ie 0.69 volts).

### 5.4 Random allocation of channels

For many of our control options we provide a range of channels to use and it is important that loads are distributed across the channels appropriately. For load control options in appendix C that are noted for random allocation, loads must be spread across the available channels. In situations where relays are ‘batch programmed’, batches must be mixed to ensure random installation in any given area or street.

### 5.5 Switching delays

To avoid sudden loading changes and associated voltage fluctuations, we require all ripple relays that operate fixed time load switching (for night time water and space heating including options with an afternoon or weekend boost) to have a random delay of 0 to 7 minutes (in at least 8 increments of no more than 1 minute) when the load is switched on.

To ensure equitable service between customers, these delays should be random for each switching operation (eg a particular customer might have a delay of 3 minutes one night, but 6 minutes the next night). As an alternative, it is satisfactory to Orion for relays to be programmed with a random delay (eg a particular customer might have a relay that always provides a 6 minute delay).

There must be no switching delay when load is turned off.

There must be no switching delay for any peak control, emergency control, or special purpose ripple channels (eg ripple relays controlling day/night meters).

## 5.6 Relay labelling

To facilitate auditing and compliance checking, we recommend that all ripple relays should be labelled to show the command channels to which they respond. The following labelling system is found on many existing ripple relays and we recommend that it continue to be used:

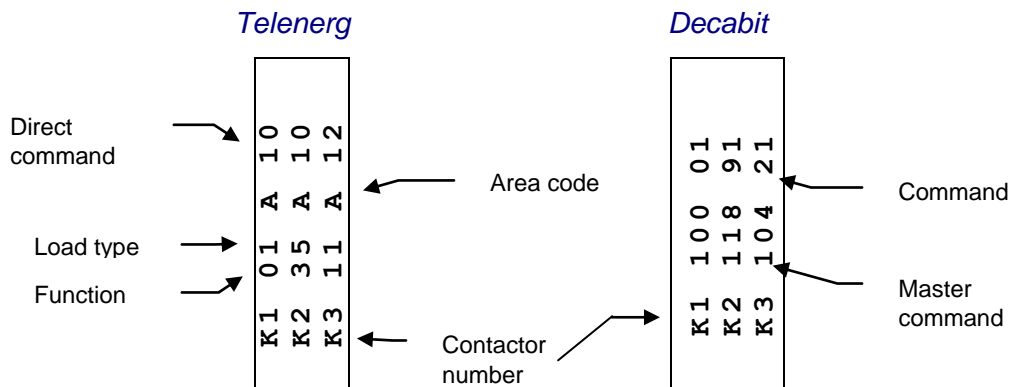

Both labels are examples of ripple relays that support a day/night retail tariff, where contactor 2 switches a dual register meter, contactor 3 switches the water cylinder on at night, and contactor 1 provides peak interruption to the customer's water heating override switch.

## 5.7 Intended channel usage

The intended use (function or purpose) of each channel is noted in our schedule of ripple relay control channels in section 3 above. We carefully consider these when determining how and when to operate the channels, and to avoid future issues, we recommend that ripple channels only be used for their intended purpose. Specifically:

- meter register switching channels should not be used to switch loads,
- peak period, control period, and generation period channels may be used to directly switch loads or generators, but we consider this to be a discretionary customer response, and
- consider installing time clock switches to control loads other than storage water heaters and storage space heaters.

## 5.8 Override or boost switches

It has been common practice to install override switches (wired in parallel with the night-rate relay) to enable customers with night-rate water heating to manually boost their hot water during the day. To comply with Orion's mandatory requirement for control of water heaters (see 2.1 above), the override switch must be wired in series with either a peak or emergency control relay, to ensure that Orion has access to interrupt any load during emergencies.



## 6 Ripple relay programming

### 6.1 Programming Telenerg relays

Orion uses a customised non-standard Telenerg coding system as described in this section. Telenerg coded relays that do not follow Orion's coding system may not function correctly.

Our 175Hz Telenerg telegram consists of one start pulse (with a length of 1650 milliseconds and a pause of 600 milliseconds) followed by up to 50 information pulse positions with a length of 1000 milliseconds (and in each pulse position, the ripple pulse may be present for the first 400 milliseconds). The information pulse positions have two zones: a preselection zone consisting of pulse positions 1 to 16 inclusive, and a direct command zone consisting of pulse positions 17 to 50 inclusive.

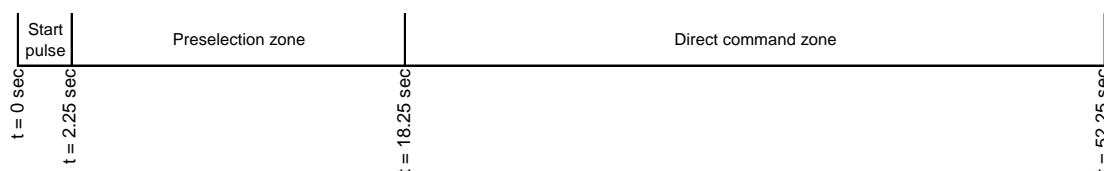

A telegram can be interrupted and replaced by the start pulse of a new telegram at any point during the preselection or direct command zones. Orion's system is non-standard in that relays must be programmed to respond to a restart pulse (truncating a running telegram) that always starts 100 milliseconds after the beginning of the 600 milliseconds pause between information pulse positions.

Telegrams can be variable length, with a minimum length of 17 pulse positions (in which the first direct command pulse in position 17 is an *on* pulse) and a maximum of 50 pulse positions (in which the last direct command pulse in position 50 is an *off* pulse). Our ripple controllers combine multiple switching instructions into a single telegram wherever possible (see example below).

The main advantage of the Telenerg system is the ability to combine ripple relays into many different master groupings (to be switched by the same telegram) and the almost limitless number of channels available.

### Coding for the preselection zone

The preselection zone spans the first 16 pulse positions and is subdivided into three groups to perform:

- Function selection (positions 1 to 4)

Pulse position				Function number
1	2	3	4	(as detailed in appendix c)
+	+	-	-	0
+	-	+	-	1
+	-	-	+	2
-	+	+	-	3
-	+	-	+	4

(+ means pulse is present, - means pulse is absent)

- Load type selection (positions 5 to 10)

Pulse position						Load type number
5	6	7	8	9	10	(as detailed in appendix c)
+	0	+	-	0	-	1
+	0	0	-	+	-	2
+	-	+	0	0	-	3
+	-	+	-	0	0	4
+	-	0	0	+	-	5
+	-	0	-	+	0	6

(+ means pulse is present, - means pulse is absent, 0 means the pulse should not be considered)

- Area selection (positions 11 to 16)

The area selection positions on all ripple relays must be programmed to respond to:

Pulse position						Area code
11	12	13	14	15	16	(as detailed in appendix c)
+	0	+	-	0	-	A

(+ means pulse is present, - means pulse is absent, 0 means the pulse should not be considered)



Of the 10 information pulse positions, 5 must be on (pulse present) and 5 must be off (pulse absent), giving 252 possible combinations, which represents 126 on/off pairs. Within these on/off pairs, the off telegrams are the inverse of on telegrams (ie where a pulse is present in a position in the on telegram, it is absent in that position in the off telegram and vice versa).

The main advantages of the Decabit coding system is the speed of transmission (6.6 seconds), and its reliability (for a false signal to occur, one pulse would need to be added and another removed, which is unlikely).

*Exception to the Decabit standard*

Orion's allocation's of commands does not fully comply with the Decabit standard; some Decabit single commands for irrigation interruptibility have been allocated to master commands that are not implicitly related to them by the Decabit command structure. The Decabit command channels affected are 32, 33 and 34, which we have assigned to master 107, rather than the Decabit standard 106.

To accommodate this difference, connections that use irrigation interruptibility command channels 32, 33 or 34 must be fitted with ripple receivers that can respond to two different telegrams. The first entry should be coded to respond to the actual command channel 32, 33 or 34 (but not the master 106), and the second entry should be coded to respond to the master 107 (but not a specific channel).

*Defined Decabit telegrams*

The following table provides the telegram sequence for all pre-defined Decabit single command allocations. "Off" telegrams are the inverse of "on" telegrams. Please note that not all single command allocations are used in our network.

Cmd No (as detailed in appendix c)	On telegram (positions 1 to 10)	Off telegram (positions 1 to 10)	Cmd No (as detailed in appendix c)	On telegram (positions 1 to 10)	Off telegram (positions 1 to 10)
00	---+---+---	+++-----+	50	++++-----	-----+++++
01	+---+---+---	-++-----+	51	++-+---+---	--+---+---+
02	+-+---+---+	-+-+---+---+	52	+---+---+---	+---+---+---
03	+++---+---+	---+---+---	53	---+---+---	---+---+---
04	----+---+---	++++---+---	54	+---+---+---	-+-+---+---
05	++-+---+---	--+---+---+	55	+++---+---+	---+---+---
06	+++---+---+	---+---+---	56	+++---+---+	---+---+---
07	++-+---+---	--+---+---+	57	+---+---+---	-+-+---+---
08	+---+---+---	-++-----+	58	-+-+---+---	+---+---+---
09	---+---+---	+++-----+	59	+++---+---+	---+---+---
10	+---+---+---	-+-+---+---	60	+++---+---+	---+---+---
11	+-+---+---+	-+-+---+---	61	-+-+---+---	+---+---+---
12	+---+---+---	-+-+---+---	62	-+-+---+---	+---+---+---
13	+---+---+---	-+-+---+---	63	+---+---+---	-+-+---+---
14	---+---+---	+++---+---+	64	+++---+---+	-+-+---+---
15	---+---+---	+++---+---+	65	+++---+---+	---+---+---
16	---+---+---	+++---+---+	66	+++---+---+	---+---+---
17	+---+---+---	-+-+---+---	67	+---+---+---	-+-+---+---
18	+---+---+---	-+-+---+---	68	-+-+---+---	+---+---+---
19	+---+---+---	-+-+---+---	69	+---+---+---	-+-+---+---
20	+---+---+---	-+-+---+---	70	-+-+---+---	+---+---+---
21	+---+---+---	-+-+---+---	71	+---+---+---	-+-+---+---
22	+---+---+---	-+-+---+---	72	-+-+---+---	+---+---+---
23	-+-+---+---	+---+---+---	73	+---+---+---	-+-+---+---
24	+---+---+---	-+-+---+---	74	-+-+---+---	+---+---+---

Cmd No (as detailed in appendix c)	On telegram (positions 1 to 10)	Off telegram (positions 1 to 10)	Cmd No (as detailed in appendix c)	On telegram (positions 1 to 10)	Off telegram (positions 1 to 10)
25	+ - - - - + - - - -	- - - - - + - - - -	75	+ + + - - - - + - -	- - - + + - - - - +
26	+ + - - - + - - - -	- - - + + - - - - +	76	+ - - + - - - + - -	- - - + + - - - - +
27	+ - - + - - - + - -	- - - + - - - + - -	77	+ - - + - - - + - -	- - - + - - - + - -
28	+ - - + - - - + - -	- - - + - - - + - -	78	- - - + - - - + - -	+ - - + - - - + - -
29	+ - - + - - - + - -	- - - + - - - + - -	79	+ - - + - - - + - -	- - - + - - - + - -
30	+ - - + - - - + - -	- - - + - - - + - -	80	- - - + - - - + - -	+ - - + - - - + - -
31	+ - - + - - - + - -	- - - + - - - + - -	81	- - - + - - - + - -	+ - - + - - - + - -
32	+ - - + - - - + - -	- - - + - - - + - -	82	- - - + - - - + - -	+ - - + - - - + - -
33	+ - - + - - - + - -	- - - + - - - + - -	83	- - - + - - - + - -	+ - - + - - - + - -
34	+ - - + - - - + - -	- - - + - - - + - -	84	- - - + - - - + - -	+ - - + - - - + - -
35	+ + - - - + - - - -	- - - + - - - + - -	85	- - - + - - - + - -	+ - - + - - - + - -
36	+ + - - - + - - - -	- - - + - - - + - -	86	- - - + - - - + - -	+ - - + - - - + - -
37	+ + - - - + - - - -	- - - + - - - + - -	87	- - - + - - - + - -	+ - - + - - - + - -
38	+ + - - - + - - - -	- - - + - - - + - -	88	- - - + - - - + - -	+ - - + - - - + - -
39	- - - + - - - + - -	+ - - + - - - + - -	89	- - - + - - - + - -	+ - - + - - - + - -
40	+ - - + - - - + - -	- - - + - - - + - -	90	+ - - + - - - + - -	- - - + - - - + - -
41	- - - + - - - + - -	+ - - + - - - + - -	91	- - - + - - - + - -	+ - - + - - - + - -
42	+ - - + - - - + - -	- - - + - - - + - -	92	- - - + - - - + - -	+ - - + - - - + - -
43	+ - - + - - - + - -	- - - + - - - + - -	93	+ - - + - - - + - -	- - - + - - - + - -
44	+ - - + - - - + - -	- - - + - - - + - -	94	+ - - + - - - + - -	- - - + - - - + - -
45	+ - - + - - - + - -	- - - + - - - + - -	95	- - - + - - - + - -	+ - - + - - - + - -
46	+ - - + - - - + - -	- - - + - - - + - -	96	- - - + - - - + - -	+ - - + - - - + - -
47	+ + - - - + - - - -	- - - + - - - + - -	97	- - - + - - - + - -	+ - - + - - - + - -
48	+ + - - - + - - - -	- - - + - - - + - -	98	- - - + - - - + - -	+ - - + - - - + - -
49	+ - - + - - - + - -	- - - + - - - + - -	99	- - - + - - - + - -	+ - - + - - - + - -

(+ means pulse is present, - means pulse is absent)

Master No (as detailed in appendix c)	On telegram (positions 1 to 10)	Off telegram (positions 1 to 10)	Master No (as detailed in appendix c)	On telegram (positions 1 to 10)	Off telegram (positions 1 to 10)
100	+ - - - - + - - - -	- - - + - - - + - -	110	+ + + - - - - + - -	- - - + - - - + - -
101	- - - + - - - + - -	+ - - + - - - + - -	111	+ + + - - - - + - -	- - - + - - - + - -
102	+ - - + - - - + - -	- - - + - - - + - -	112	+ - - + - - - + - -	- - - + - - - + - -
103	+ - - + - - - + - -	- - - + - - - + - -	113	+ - - + - - - + - -	- - - + - - - + - -
104	+ - - + - - - + - -	- - - + - - - + - -	114	+ - - + - - - + - -	- - - + - - - + - -
105	+ - - + - - - + - -	- - - + - - - + - -	115	+ - - + - - - + - -	- - - + - - - + - -
106	+ - - + - - - + - -	- - - + - - - + - -	116	- - - + - - - + - -	+ - - + - - - + - -
107	- - - + - - - + - -	+ - - + - - - + - -	117	- - - + - - - + - -	+ - - + - - - + - -
108	+ - - + - - - + - -	- - - + - - - + - -	118	+ - - + - - - + - -	- - - + - - - + - -
109	+ - - + - - - + - -	- - - + - - - + - -			

(+ means pulse is present, - means pulse is absent)

Pulse pairs numbered 119 through 125 are reserved for special features under the Decabit coding system and are not used by Orion.

Decabit ripple relays must only be programmed to respond to master command numbers where a master command number is given in appendix C.

### Decabit telegram example

As an example, the following Decabit telegram would switch **on** ripple receivers coded for 104-20 (night only), using the command channel not the master command channel.

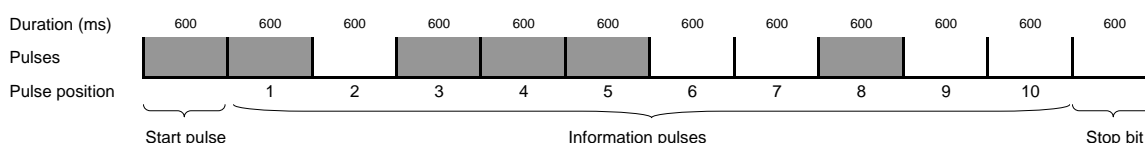

## Appendix A – Orion ripple control coding by area

Geographic area	Transpower Grid Exit Point	Ripple Coding System
Mainly urban Winter peaking	Addington 66kV (ADD0661)	Telenerg
	Addington 11kV 1&2 (ADD0111)	Telenerg
	Islington 66kV (ISL0661)	Telenerg
	Islington 33kV (ISL0331)	Telenerg (a transitional Decabit signal is provided in area A in appendix B until May 2017)
	Bromley 66kV (BRY0661)	Telenerg
	Middleton 66kV (MLN0661)	Telenerg
	Middleton 66kV (MLN0664)	Telenerg
	Bromley 11kV (BRY0111)	Telenerg
	Papanui 66kV (PAP0661)	Telenerg
	Papanui 11kV 1&2 (PAP0111)	Telenerg
	Arthurs Pass 11kV (APS0111)	No ripple injection
	Castle Hill 11kV (CLH0111)	
	Coleridge 11kV (COL0111)	
Mainly rural	Hororata 33kV (HOR0331)	Decabit
	Hororata 66kV (HOR0661)	Decabit
	Springston 33kV (SPN0331)	Decabit
	Springston 66kV (SPN0661)	Decabit

## Appendix B – Telenerg / Decabit boundary

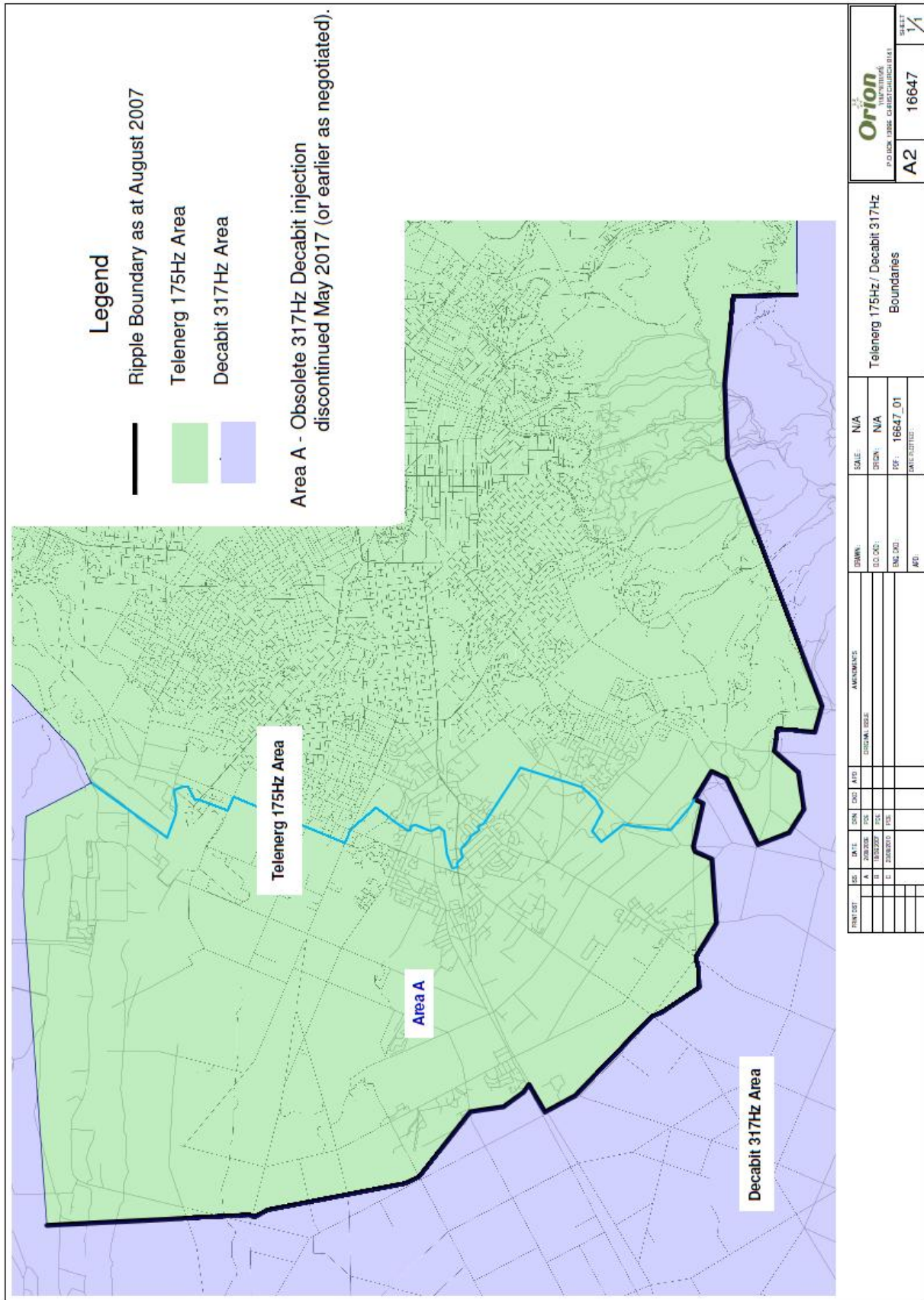

## Appendix C – Ripple receiver control channels

Option Reference & Name	Comments	Switching delay	Switch position	Telenerg channels (function, load type, area code*, direct command)		Decabit channels (master command, command)	
<b>Peak load control</b>							
P1 Peak control	Generally off for up to 250 hours per year. Aim to limit control to no more than 4 hours in any 8 hour period,.Allocate randomly across available channels.	On: Nil Off: Nil	Normally on (switched off during control)	01 A 10 01 A 11 01 A 12 01 A 13 01 A 14 01 A 15 01 A 16 01 A 17	01 A 18 01 A 19 01 A 20 01 A 21 01 A 22 01 A 23 01 A 24 01 A 25	100 00 100 02 100 03 100 04 100 05	100 06 100 07 100 08 100 09 100 10
P2 Peak control (business)	Aim to limit control to no more than 2 hours in any 5 hour period. Allocate randomly across available channels.	On: Nil Off: Nil	Normally on (switched off during control)	02 A 10 02 A 11 03 A 10 03 A 13		100 14 100 01	
<b>Fixed time load control</b>							
F1 Night only	Provides approximately 7½ hours per night in one or two blocks, between the hours of 9pm and 7am. For Telenerg, allocate randomly across available channels. For Decabit, allocate to channels marked in bold.	On: 0-7 min Off: Nil	Normally off (switched on at night)	11 A 10 11 A 11 11 A 12 11 A 13 11 A 14 11 A 15 11 A 16 11 A 17	11 A 18 11 A 19 11 A 20 11 A 21 11 A 22 11 A 23 11 A 24 11 A 25	104 20 104 21 104 22 104 23	116 80 116 81 116 82
F2 Night with afternoon boost	As above but with an additional 3 hour boost between the hours of 12pm and 4pm in the afternoon. Allocate randomly across available channels.	On: 0-7 min Off: Nil	Normally off (switched on at night and during boost)	12 A 10 12 A 11		106 30 106 31	
F3 Nights and weekends	As above but with an additional 4 hour boost between the hours of 9am and 4pm on Saturdays and Sundays. Allocate randomly across available channels.	On: 0-7 min Off: Nil	Normally off (switched on at night and during boost)	14 A 10 14 A 11		108 40	
F4 Night 8 (reserved)	Reserved channel for use with Orion's approval. Provides approximately 8 hours per night in one block.	On: 0-7 min Off: Nil	Normally off (switched on at night)	15 A 16		117 88	

Every Telenerg relay must respond to its master (09) direct command - see page 19



Option Reference & Name	Comments	Switching delay	Switch position	Telenerg channels (function, load type, area code*, direct command)	Decabit channels (master command, command)
<b>Emergency load control</b>					
E1 Emergency control (residential)	Expect less than 2 events per year, lasting up to 2 hours (longer in extreme circumstances).	On: Nil Off: Nil	Normally on (switched off during emergencies)	03 A 11	100 13
E2 Emergency control (business)	As above, but given priority for restoration of supply.	On: Nil Off: Nil	Normally on (switched off during emergencies)	03 A 12	100 15
E3 Emergency control (irrigation)	Selectively interrupts irrigation loads during emergencies (associated with Orion's <i>Interruption Rebate</i> ). Expect maximum of 8 hours once in every 5 years, and 48 hours once in every 10 years. Channel allocation determined by Orion (phone 0800 363 9898 for details).	On: Nil Off: Nil	Normally on (switched off during emergencies)		105 25 107 32 105 26 107 33 105 27 107 34 105 28 107 35 105 29 107 36 107 37 107 38 107 39
<b>Special purpose channels</b>					
S1 General connection peak period	Pricing signal for general connections indicating the occurrence of a peak period. Target 100 to 150 hours per year. Allocate randomly across available channels.	On: Nil Off: Nil	Normally off (switched on during peak period)	21 A 10 21 A 11	52
S4 Major customer control period (G1)	Pricing signal for major customer connections indicating the occurrence of a control period (for group 1 connections). Target 80 to 100 hours per year. Channel allocation determined by Orion.	On: Nil Off: Nil	Normally off (switched on during control period)	32 A 15	56
S5 Major customer control period (G2)	As above, but for connections in group 2. Channel allocation determined by Orion.	On: Nil Off: Nil	Normally off (switched on during control period)	32 A 16	53
S6 Generation period	Pricing signal for Orion's generation credits. Varies year to year (expect nil to 25 hours).	On: Nil Off: Nil	Normally off (switched on during generation period)	32 A 18	57
S7 Street lighting	For switching of private and public streetlighting. On at night using either an ephemeris clock or light sensor (by area).	On: Nil Off: Nil	Normally off (switched on at night)	41 A 10	47
S8 Street lighting (Victoria Square)	For switching of streetlighting in and around Victoria Square (to enable separate control during events). On at night using either an ephemeris clock or light sensor (by area).	On: Nil Off: Nil	Normally off (switched on at night)	44 A 10 44 A 11 44 A 12 44 A 13	
S9 Day / Night meter switching	For switching dual rate day/night meters. Switched on from 9pm till 7am.	On: Nil Off: Nil	Normally off (switched on at night)	35 A 11	91
S10 Night & weekend meter switching	For switching dual rate day/night & weekend meters. Switched on from 9pm till 7am plus all day Saturday and Sunday.	On: Nil Off: Nil	Normally off (switched on at night)	32 A 11	51

Every Telenerg relay must respond to its master (09) direct command - see page 19

S11 Meridian control 1	Reserved for use by Meridian.	On: Nil Off: Nil	Normally off	32 A 19	111 60
S12 Meridian control 2	Reserved for use by Meridian.	On: Nil Off: Nil	Normally off	32 A 20	111 61
S13 Optional load switching (7h)	For switching customer owned ripple receivers, for example, Enermet SwitchIt relays or DRF relays (generally installed with night store heaters). Provides approximately 7 hours per night in one block.	On: Nil Off: Nil	Normally off (switched on at night)	15 A 15	116 84
S14 Optional load switching (8h)	As above but provides approx 8 hours per night in one block.	On: Nil Off: Nil	Normally off (switched on at night)	15 A 14	116 83

**Obsolete channels** (Orion intends to withdraw these channels after December 2012)

Ob1 Day / Night meter switching (obsolete)	Obsolete – use option S9. For switching dual rate day/night meters (incl open 24 and family 8 meters). Switched on from 9pm till 7am.	On: Nil Off: Nil	Normally off (switched on at night)	35 A 10 35 A 12 32 A 10	90 92 50
Ob2 Night only (obsolete)	Obsolete – use option F1. Provides approximately 7½ hours per night in one or two blocks, between the hours of 9pm and 7am.	On: 0-7 min Off: Nil	Normally off (switched on at night)	15 A 12 15 A 11 15 A 10	
Ob5 Night with afternoon boost (obsolete)	Obsolete – use option F2. As above but with an additional 3 hour boost between the hours of 12pm and 4pm in the afternoon.	On: 0-7 min Off: Nil	Normally off (switched on at night and during boost)	16 A 10 to 16 A 12 12 A 12 to 12 A 25	117 87 117 86 117 85
Ob8 Night rate (obsolete)	Obsolete – use option F1. Provides an option similar to Night only, but switching both loads and meters. Provides approximately 7½ hours per night in two blocks, between the hours of 9pm and 7am.	On: 0-7 min Off: Nil	Normally off (switched on at night)	13 A 10 to 13 A 13	
Ob9 Peak control 4h (obsolete)	Obsolete – use option P2. Aim to limit control to no more than 2 hours in any 5 hour period.	On: Nil Off: Nil			100 12

\*For new connections or modifications, ripple relays programmed with area code A should be installed in all areas. Older ripple relays with other area codes (B to F, H J and K) will continue to operate and will be controlled at the same time.

*Every Telenerg relay must respond to its master (09) direct command - see page 19*

## Appendix D – Ripple receiver fixed switching times

	Daily		Daily		Daily duration	Boost		Boost frequency	Boost duration
	On	Off	On	Off		On	Off		
<b>F1 Night only</b>									
<b>Telenerg*</b>									
11 A 10	23:28	6:58			7:30				
11 A 11	23:28	6:58			7:30				
11 A 12	23:28	6:58			7:30				
11 A 13	23:28	6:58			7:30				
11 A 14	22:13	23:25	0:35	6:53	7:30				
11 A 15	22:13	23:25	0:35	6:53	7:30				
11 A 16	22:13	23:25	0:35	6:53	7:30				
11 A 17	22:13	23:25	0:35	6:53	7:30				
11 A 18	22:58	6:28			7:30				
11 A 19	22:58	6:28			7:30				
11 A 20	22:58	6:28			7:30				
11 A 21	22:58	6:28			7:30				
11 A 22	23:13	6:43			7:30				
11 A 23	23:13	6:43			7:30				
11 A 24	23:13	6:43			7:30				
11 A 25	23:13	6:43			7:30				
<b>Decabit</b>									
104 20	22:28	5:58			7:30				
104 21	23:18	6:48			7:30				
104 22	22:48	6:18			7:30				
104 23	22:48	6:18			7:30				
116 80	23:28	6:58			7:30				
116 81	22:58	6:28			7:30				
116 82	23:08	6:38			7:30				
<b>F2 Night with afternoon boost</b>									
<b>Telenerg*</b>									
12 A 10	22:43	6:13			7:30	12:45	15:45	every day	3:00
12 A 11	22:43	6:13			7:30	12:45	15:45	every day	3:00
<b>Decabit</b>									
106 30	23:08	6:38			7:30	12:45	15:45	every day	3:00
106 31	23:08	6:38			7:30	12:45	15:45	every day	3:00
<b>F3 Nights and weekends</b>									
<b>Telenerg*</b>									
14 A 10	22:43	6:13			7:30	11:00	15:00	Sat & Sun	4:00
14 A 11	22:43	6:13			7:30	11:00	15:00	Sat & Sun	4:00
<b>Decabit</b>									
108 40	22:38	6:08			7:30	11:00	15:00	Sat & Sun	4:00
<b>F4 Night 8 (reserved)</b>									
<b>Telenerg*</b>									
15 A 16	22:28	6:28			8:00				
<b>Decabit</b>									
117 88	22:18	6:18			8:00				

	Daily				Daily duration	Boost		Boost frequency	Boost duration
	On	Off	On	Off		On	Off		
<b>S7 Street lighting</b>									
<b>Telenerg*</b>									
41 A 10	Uses either ephemeris clock or light sensor (by area).								
<b>Decabit</b>									
47	Uses either ephemeris clock or light sensor (by area).								
<b>S9 Day / Night meter switching</b>									
<b>Telenerg*</b>									
35 A 11	20:59	6:59			10:00				
<b>Decabit</b>									
91	20:59	6:59			10:00				
<b>S10 Night &amp; weekend meter switching</b>									
<b>Telenerg*</b>									
32 A 11	20:59	6:59			10:00	6:59	20:59	Sat & Sun	14:00
<b>Decabit</b>									
51	20:59	6:59			10:00	6:59	20:59	Sat & Sun	14:00
<b>S13 Optional load switching (7h)</b>									
<b>Telenerg*</b>									
15 A 15	23:58	6:58			7:00				
<b>Decabit</b>									
116 84	23:58	6:58			7:00				
<b>S14 Optional load switching (8h)</b>									
<b>Telenerg*</b>									
15 A 14	22:28	6:28			8:00				
<b>Decabit</b>									
116 83	22:18	6:18			8:00				
<b>Ob1 Day / Night meter switching (obsolete)</b>									
<b>Telenerg*</b>									
32 A 10	20:59	6:59			10:00				
35 A 10	20:59	6:59			10:00				
35 A 12	20:59	6:59			10:00				
<b>Decabit</b>									
50	20:59	6:59			10:00				
90	20:59	6:59			10:00				
92	20:59	6:59			10:00				
<b>Ob2 Night only (obsolete)</b>									
<b>Telenerg*</b>									
15 A 12	21:43	22:55	0:15	6:33	7:30				
15 A 11	21:43	22:55	0:15	6:33	7:30				
15 A 10	21:58	23:10	0:20	6:38	7:30				

	Daily				Daily duration	Boost		Boost frequency	Boost duration
	On	Off	On	Off		On	Off		
<b>Ob5 Night with afternoon boost (obsolete)</b>									
<b>Telenerg*</b>									
16 A 10 to 16 A 12	22:28	5:58			7:30	13:00	16:00	every day	3:00
12 A 12 to 12 A 25	22:43	6:13			7:30	12:45	15:45	every day	3:00
<b>Decabit</b>									
117 87	22:38	6:08			7:30	13:00	16:00	every day	3:00
117 86	22:38	6:08			7:30	13:00	16:00	every day	3:00
117 85	22:38	6:08			7:30	13:00	16:00	every day	3:00
<b>Ob8 Night rate (obsolete)</b>									
<b>Telenerg*</b>									
13 A 10 to 13 A 13	21:43	22:55	0:15	6:33	7:30				

\* Ripple relays with other area codes (B to F, H J and K) switch at the same time as ripple relays with area code A.

## Appendix E – Historical channel reference

The table below shows the previous names used for channels provided by Orion and its predecessors. Where applicable, the matching current channel option is also shown.

Old Code / Name	Description	Current option	
RR1	Residential 1	Peak control for water heating	P1
RR2	Residential 2	Peak control for water heating	P1
RM1	Power Manager Residential	Peak control for water heating	P1
RM3	Power Manager Business	Peak control for water heating (for business)	P2
RF2	Residential Family 8	Night only plus day/night meter	F1 + S9
RN6	Residential Night and Day 6	Night only day/night meter	F1 + S9
RN7	Residential Night and Day 7	Night only plus day/night meter	F1 + S9
RN8	Residential Night and Day 8	Night only plus day/night meter	F1 + S9
RM6	Power Manager Night and Day 6	Night only plus day/night meter	F1 + S9
RM7	Power Manager Night and Day 7	Night only plus day/night meter	F1 + S9
RM8	Power Manager Night and Day 8	Night only plus day/night meter	F1 + S9
BN1	Business Nightsaver	Night only with dedicated meter	F1
RS1	Residential Nightsaver Plus	Night with afternoon boost plus day/night meter	F2 + S9
BD1	Business Daysaver	Peak control for business water heaters limited to less than 2h off per day.	P2
BD2	Business Daysaver Plus	Peak control for business water heaters limited to less than 4h off per day	P2
BO1	Business Open 24	Night only with Day/night meter	F1 + S9
BL2	Business Large 2	Night only with Day/night meter	F1 + S9
BW1	Business Weekender	Weekday/ nights and weekend meter	S10
	Enterprise irrigation Discount irrigation TIP	Provided peak/off peak metering. No longer a valid price option.	Obsolete
LG4	Load Group 4	Major customers control periods	S4 or S5
P3	Peak control 4h (business)	Provided peak control limited to 4 hours per day (now combined with P2 with a 2 in 5 hour service level).	P2
S2 and S3	Major customer control period warning	Provided advance warning of major customer control periods (Telenerg channels 32A14 and 32A17, Decabit channels 54 and 55). No longer issued.	Obsolete